

# L-P Range

# Safety Guidelines

NOTE: This manual is compiled from the latest specifications and product information available at the time of publication. We reserve the right to make changes as they become necessary. Any changes to our products may cause slight variations between the illustrations and explanations in this manual. The latest/current version of this manual is available on our website.

If you require an electronic version or translated version of the manual please scan the QR code or enter the URL (<https://www.mobilityinmotion.com/Autochair-User-Manuals>) and select the appropriate manual.

**Français** - Veuillez scanner le QR Code ou entrer l'URL de la version Française du manuel d'utilisation

**Deutsch** - Bitte scannen Sie den QR-Code oder geben Sie die URL für die deutsche Version des Benutzerhandbuchs ein

**Español** - Escanee el código QR o introduzca la URL de la versión en Español del manual del usuario

**Italiano** - Scansiona il codice QR o inserisci l'URL per la versione Italiana del manuale utente

**Polski** - Zeskanuj kod QR lub wprowadź adres URL Polskiej wersji instrukcji obsługi

**Čeština** - Naskenujte prosím QR kód nebo zadejte URL pro Českou verzi uživatelské příručky

**Nederlands** - Scan de QR-code of voer de URL in voor de Nederlandse versie van de gebruikershandleiding

**תירבע** - השרגה רובע רתאה תבותב תא וזה וז QR-ה דוק תא קורט שמתשמל קירדמה לש תירבעה



**WARNING!**

The Smart Lifter is only intended to be installed by an Accredited Dealer or installer. Do not attempt to install the Smart Lifter yourself.

The following symbols are used to identify warnings and important details throughout this manual. Please read them and ensure you are aware of their meaning.



**WARNING!**

These symbols denote a potentially dangerous situation. Failure to carry out the specified procedures may result in injury or damage to the device.



**MANDATORY!**

The indicated actions must be carried out as specified. Failure to perform the specified actions may result in injury or damage to the device.



**PROHIBITED!**

Do not carry out the indicated actions. They should not be performed at any time, under any circumstances. Carrying out a prohibited action may result in injury or damage to the device.

**UK  
CA**

Copyright © 2024  
Autochair Ltd.  
1228097 Rev. E

Manufactured By:  
Autochair Ltd.  
Wood Street North  
Meadow Lane Industrial  
Estate  
Alfreton  
Derbyshire  
DE55 7JR

**CE**

EU Authorised Representative:  
Product IP AR Services  
Galvanistraat 1  
6716 AE Ede  
The Netherlands

# Contents

<b>1. INTRODUCTION .....</b>	<b>4</b>
<b>2. SAFETY .....</b>	<b>5</b>
<b>3. TECHNICAL .....</b>	<b>8</b>
<b>4. OPERATION-LOADING .....</b>	<b>10</b>
<b>5. OPERATION-UNLOADING .....</b>	<b>15</b>
<b>6. REMOVING THE SMART LIFTER.....</b>	<b>21</b>
<b>7. REPLACING THE SMART LIFTER .....</b>	<b>23</b>
<b>8. TROUBLESHOOTING .....</b>	<b>25</b>
<b>9. MAINTENANCE.....</b>	<b>26</b>
<b>10. WARRANTY.....</b>	<b>27</b>
<b>11. DEALER DETAILS .....</b>	<b>28</b>

# 1. Introduction

## **Congratulations on the purchase of your new Smart Lifter manufactured by Autochair.**

Please read through these instructions thoroughly before operating your Smart Lifter.

All models of this product are very powerful in both the UP (lifting) and DOWN (lowering) as well as the IN (into vehicle) and OUT (out of vehicle) operation. Care should be taken that the boom and mobility device are free to move. These devices have the power to break trim and cause harm if not operated correctly.

This Smart Lifter is designed to lift wheel-chairs, electric wheel-chairs and mobility devices into vehicles. They should be fitted into the vehicle by a competent fitter who will also ensure that the correct lifting bracket is fitted to suit your mobility vehicle. The fitter will also demonstrate the operation of your Smart Lifter and show you how the lifting brackets are connected.

Please note that your Smart Lifter comes complete with a warranty as detailed in your contract. This warranty covers the replacement of any faulty parts. The warranty does not cover travel costs.

### **END-USER'S AGREEMENT**

By accepting delivery of this Smart Lifter, you agree that you will not modify, change or alter this product or remove or render inoperable or unsafe any guards, shields, or other safety features of this product; fail, refuse, or neglect to install any retrofit kits from time to time provided by Autochair to enhance or preserve the safe use of this product.

### **FEEDBACK AND SUGGESTIONS**

We want to hear your questions, comments, and suggestions about this manual. We would also like to hear about the safety and reliability of your new Smart Lifter and about the service you received from your Accredited Dealer.

Please notify us of any change of address, so we can keep you apprised of important information about safety, new products, and new options that could improve your ability to use and enjoy your lift system.



## 2. Safety

### PRODUCT SAFETY SYMBOLS

Please study the symbols below to ensure you understand them completely. They are used on the Smart Lifter and in the manual to identify warnings and mandatory or prohibited actions.



Read and follow all directions in this manual.



The maximum lifting capacity of the Smart Lifter is dependent on the version you have purchased. Check this by referring to labels on the lift arm. The mobility device must not exceed this weight.



Do not ride on the mobility product while operating the Smart Lifter or when the vehicle is in motion.



Pinch/Crush points on the Smart Lifter. Keep hands and fingers away from moving components and crush points when operating the Smart Lifter.



Battery posts, terminals and related accessories contain lead and lead compounds. Wear goggles and gloves when handling batteries and wash hands after handling.





Disposal and recycling. Contact your Accredited Dealer for information on proper disposal of your Smart Lifter and its packaging.

## 2. Safety



### LIFTING CAPACITIES

This Smart Lifter is designed to lift a maximum weight dependent on the version that you have purchased. Check this by referring to labels on the lift arm. Under no circumstances should the Smart Lifter exceed the stated lifting capacity. Subjecting the Smart Lifter to the strain of lifting more than it is designed to may cause it to fail, resulting in damage to the mobility product and/or injury to the operator. Refer to the mobility product specifications for information on the overall weight of the mobility product before lifting with the Smart Lifter.

	<b>WARNING!</b> Do not exceed the maximum stated lifting capacity.
	<b>MANDATORY!</b> Adding accessories, oversized batteries, or a different seat will increase the weight of your mobility device. Verify with your mobility device supplier to ensure your mobility device does not exceed the maximum lift capacity of the Smart Lifter.
	<b>WARNING!</b> The Fitting Kit and Accessories for your vehicle may be rated at a lower capacity than your Smart Lifter. Please check with your Accredited Dealer to ensure the correct Safe Working Load is maintained.

### PRE-USE INSPECTION

There should be no sharp edges on the Smart Lifter, the A-Frame or the lifting bracket. If you find any sharp edges, please contact your Accredited Dealer and notify them. Make sure that you are completely happy with the operation of your Smart Lifter before lifting your mobility device. Misuse or incorrect operation of the Smart Lifter could result in injury. Inspect the lifting straps before every use for twisting, fraying or signs of wear. If signs of wear become evident, have them replaced by your Accredited Dealer.

	<b>WARNING!</b> A frayed or worn strap can snap, resulting in damage to the Smart Lifter and mobility device and potentially injury to the operator.
	<b>MANDATORY!</b> If your mobility device changes; contact your Accredited Dealer to confirm suitability with your existing Smart Lifter before use.

### OPERATOR POSITIONING

Keep hands and fingers clear of the lift arm while the lift system is lifting/lowering or loading in/out a mobility product. The operator should stand a safe distance from the Smart Lifter when it is in operation to ensure that their feet are never positioned under a raised mobility product.









### VEHICLE POSITIONING

Be sure your vehicle is parked on flat, level ground and the handbrake is engaged before attempting to lift a mobility product. Before lowering ensure that the Smart Lifter is fully out of the vehicle, otherwise your mobility device may come into contact with your vehicles bumper.

**Before lifting the mobility product for the first time, operate the Smart Lifter without a load until you are familiar with the controls and how the Smart Lifter operates.**

Any adjustment to the Smart Lifter settings must only be carried out by an Accredited Dealer. If in doubt about any aspect of your Smart Lifter, please contact your Accredited Dealer.

## 2. Safety

	<p><b>WARNING!</b> Attempting to lift a mobility device when a vehicle is not on level ground will cause the mobility product to swing toward or away from the vehicle, making it difficult to get the mobility product into the vehicle.</p>
	<p><b>WARNING!</b> The Smart Lifter must never be operated by a child or any person not deemed appropriate by the technician who installed it.</p>
	<p><b>WARNING!</b> The safety ("R"-Clip) must be fitted into the top pin in the A-Frame before operating.</p>
	<p><b>WARNING!</b> Note the position of all pinch point warning labels stating "Keep Clear". Never place your hands in these locations when the Smart Lifter is in operation.</p>
	<p><b>WARNING!</b> The Smart Lifter must never be used to lift items other than the mobility product it was originally installed and set-up to lift. If you wish to lift additional mobility products, contact your Accredited Dealer.</p>
	<p><b>WARNING!</b> Never use a Smart Lifter that has signs of damage or excessive wear.</p>
	<p><b>WARNING!</b> Misuse of the Smart Lifter may result in serious injury and damage to the unit, vehicle or operator.</p>
	<p><b>WARNING!</b> The actuator must be replaced before 6 years pass from date of purchase.</p>
	<p><b>WARNING! Magnetic interference and medical devices</b></p> <p>The Smart Lifter handset contains a magnet to allow it to connect to the A-Frame when the product is not in use.</p> <p>Under certain conditions, magnets and electromagnetic fields might interfere with active implanted medical devices. For example, implanted pacemakers may contain sensors that respond to magnets when used in close contact. To avoid any potential interference with these types of medical devices, keep the handset a safe distance away from your medical device (more than 154mm /6 Inches apart). Consult with your physician and your device manufacturer for specific guidelines.</p> <p>If you suspect that your Smart Lifter handset is interfering with your medical device, consult your physician and your medical-device manufacturer.</p>

# 3. Technical

## 4 - Way Control

### Illustrated Parts

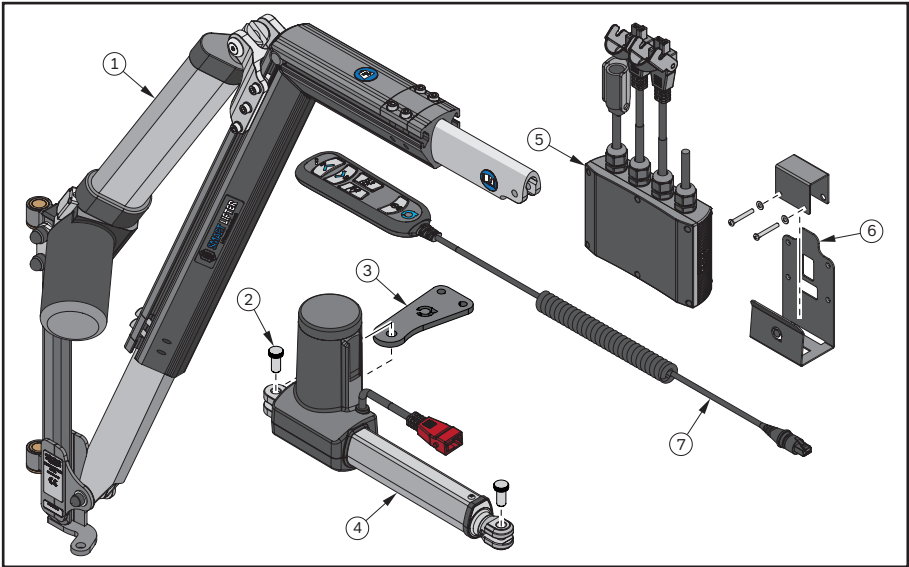

### Illustrated Parts List

Item No.	Description	Qty.
1	Smart Lifter - LP Range	1
2	Knurled Pin	2
3	In/Out Actuator Bracket	1
4	In/Out Actuator	1
5	4 - Way Control Box	1
6	Control box bracket	1
7	Four Way Handset	1



**MANDATORY!** Your Smart Lifter is set up for the mobility device used at the time of installation. If you change your mobility device in any way, contact your Accredited Dealer to have your Smart Lifter adjusted to suit your new mobility device.

### PRODUCT SPECIFICATIONS

Smart Lifter Model	L-P100	L-P125	L-P150	L-P200
Maximum lifting capacity:	100Kg (220lbs)	125Kg (275lbs)	150Kg (330lbs)	200Kg (440lbs)

# 3. Technical

## Handset Control Features

### Button Functions

When a button is pressed the selected button will illuminate brighter than the unselected keys.

ON/OFF BUTTON



UP BUTTON

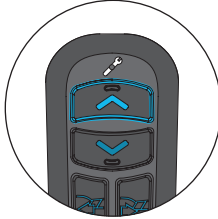

DOWN BUTTON

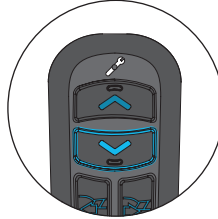

OUT BUTTON

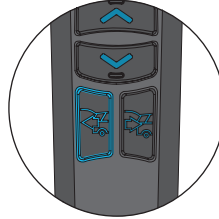

IN BUTTON

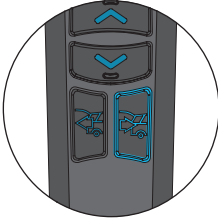

### Key Functions

ON/OFF BUTTON

= Press and release for power ON/OFF. If backlit can be seen, the Smart Lifter is ON, if not it's OFF.

UP BUTTON

= Press and hold for the Smart Lifter Arm to move up.

DOWN BUTTON

= Press and hold for the Smart Lifter Arm to move down.

OUT BUTTON

= Press and hold for Smart Lifter move out.

IN BUTTON

= Press and hold for Smart Lifter move in.

### Overcurrent Protection (OCP)

Overcurrent Protection is incorporated into the system to prolong the life of your Smart Lifter. If the system detects too much current is being drawn, the power to the system will be cut out for 3 seconds. This may occur if the spreader bar or mobility device hits/comes into contact with an obstacle or if the lifting load is greater than the Smart Lifters lifting capacity/lifting weight limit.

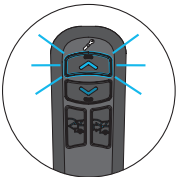

When engaging the UP BUTTON on the handset and OCP is triggered, the button will flash for the duration it is pressed and for 3 seconds after it is released.

During OCP (and for 3 seconds after release) the UP BUTTON is disabled. After the 3 seconds the handset will return to the ON state and all buttons will function.

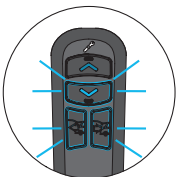

When engaging the DOWN, OUT or IN BUTTON on the handset and OCP is triggered, the selected button will flash for the duration it is pressed and for 3 seconds after it is released.

During OCP (and for 3 seconds after release) ALL BUTTONS are disabled except for the ON/OFF BUTTON. After the 3 seconds the handset will return to the ON state and all buttons will function.



### Service Light Warning

The handset has a built in service warning light underneath the spanner icon. If the warning light comes on contact your original installer to arrange for the hoist to be serviced.

**Note:** Please be advised that the handset is still functional when the service light displays.

### Auto Shut Down

If there is no operation on the handset for 5±0.5 minutes the system turns off automatically. The backlit will disappear, indicating unit is turned off.

## 4. Operation - Loading

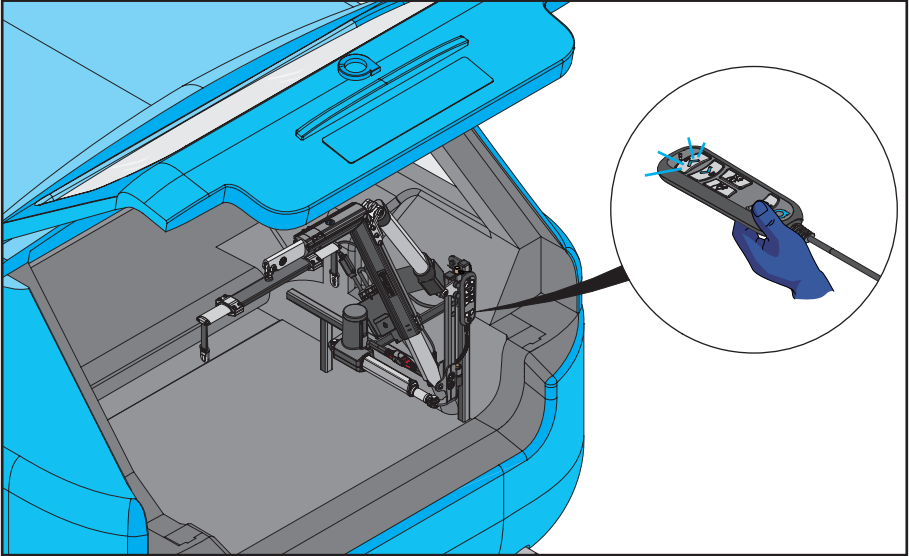

1. Smart Lifter in position in the boot of the vehicle. Using the handset press the ON/OFF BUTTON on the remote as shown. This will illuminate the remote and turn on the hoist.

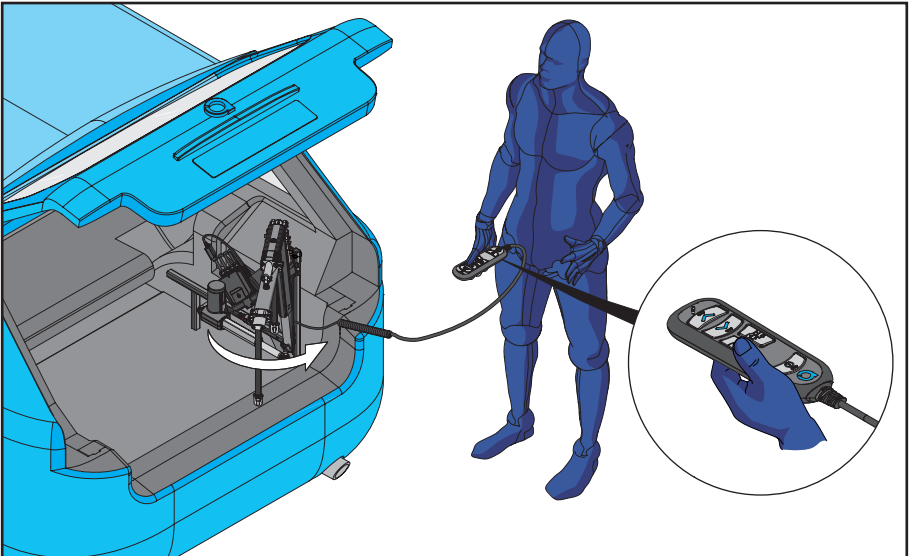

2. Press and hold the OUT BUTTON as shown. Release the OUT BUTTON once the Smart Lifter is in the fully out position.

## 4. Operation - Loading

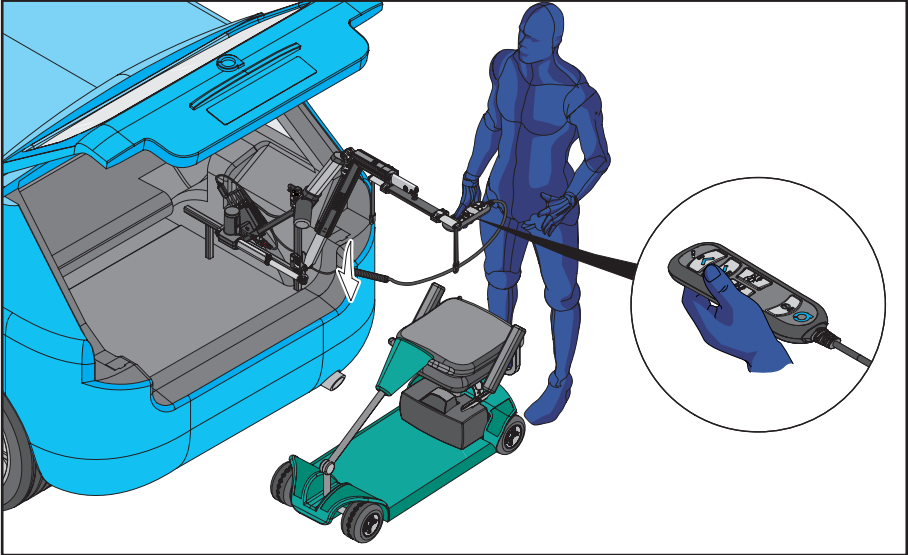

3. Smart Lifter shown in the fully out position. Press and hold the DOWN BUTTON to move the spreader bar towards the mobility device. Release the DOWN BUTTON when the spreader bar is at the desired height.

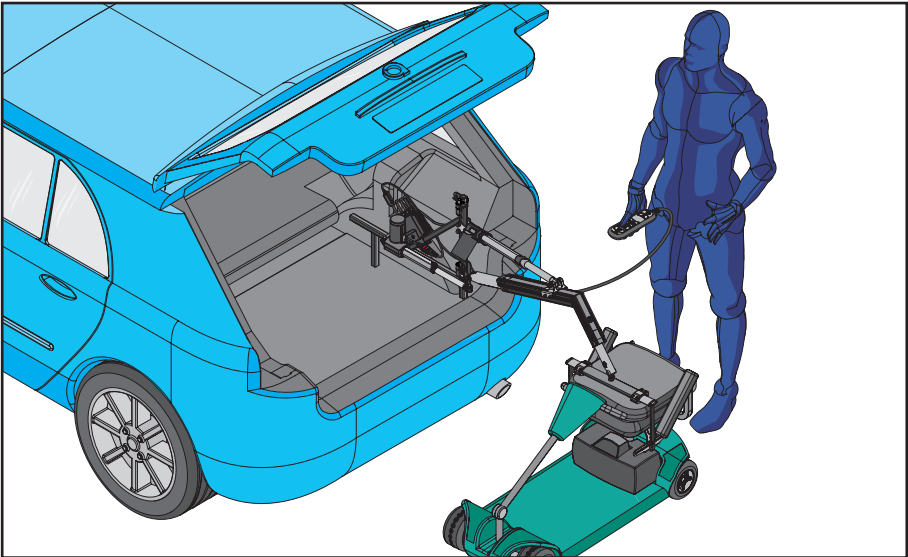

4. Smart Lifter shown in position above the mobility device.



**When Lifting/Lowering the Smart Lifter do not hold or steady the Smart Lifter Arm.**



**When lowering the Smart Lifter DO NOT continue to hold the DOWN BUTTON when the Spreader bar is touching the mobility device. This can cause damage to the mobility device and the hoist.**

## 4. Operation - Loading

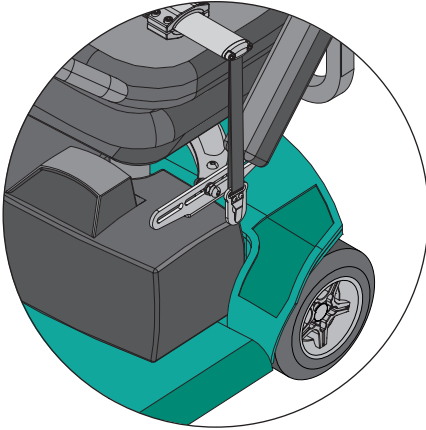

5. Attach the spreader bar to the connection points on the lifting bracket.

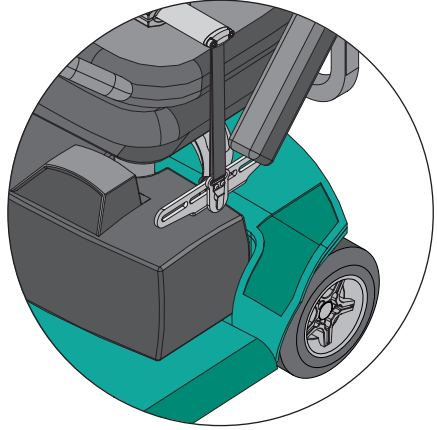

6. Ensure that the lifting points are securely attached. **DO NOT** attempt to lift without all lifting straps securely connected.

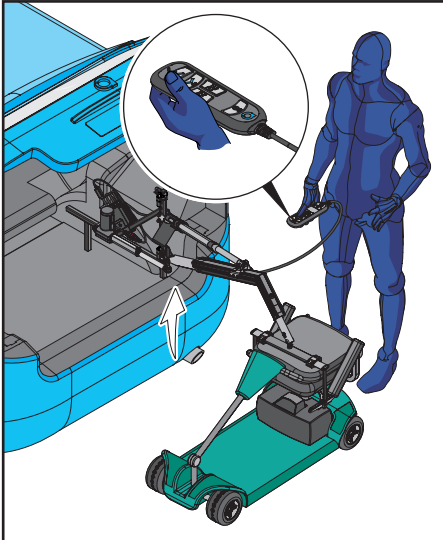

7. Press and hold the UP BUTTON on the handset.

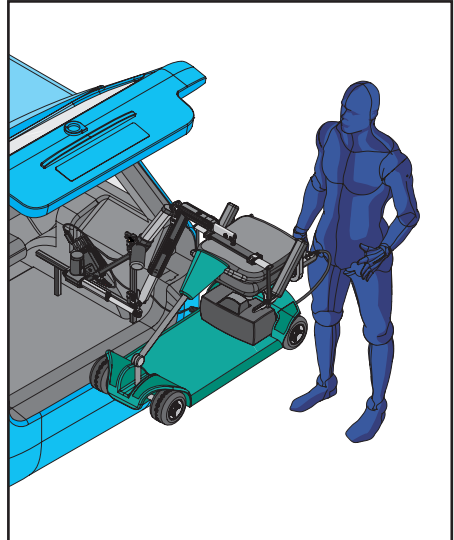

8. Release the UP BUTTON once the Smart Lifter is at the highest point. Ensure the mobility device is level.



**When Lifting/Lowering the Smart Lifter do not hold or steady the Smart Lifter Arm.**



**The operator should stand a safe distance from the Smart Lifter when it is in operation to ensure that no part of their body is positioned under a raised mobility device.**



## 4. Operation - Loading

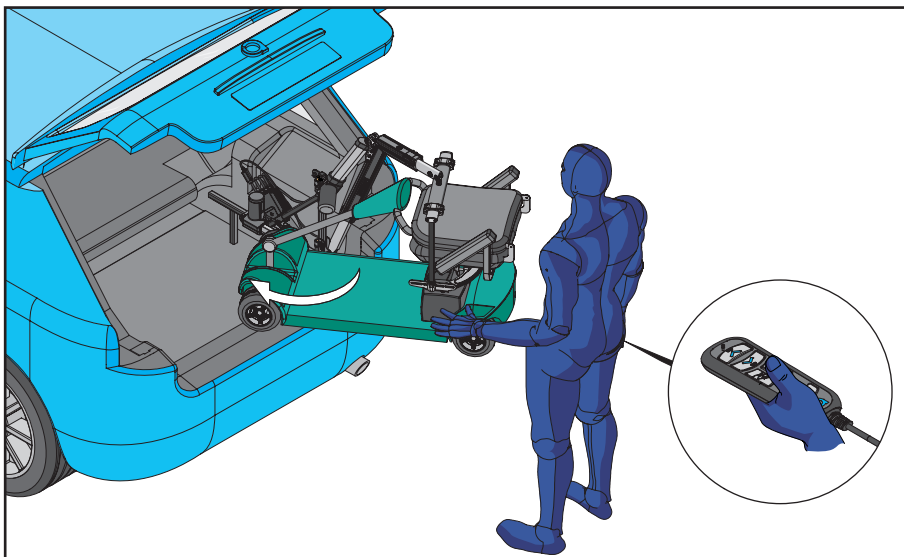

9. Rotate the mobility device to face into the vehicle. Press and hold the IN BUTTON.

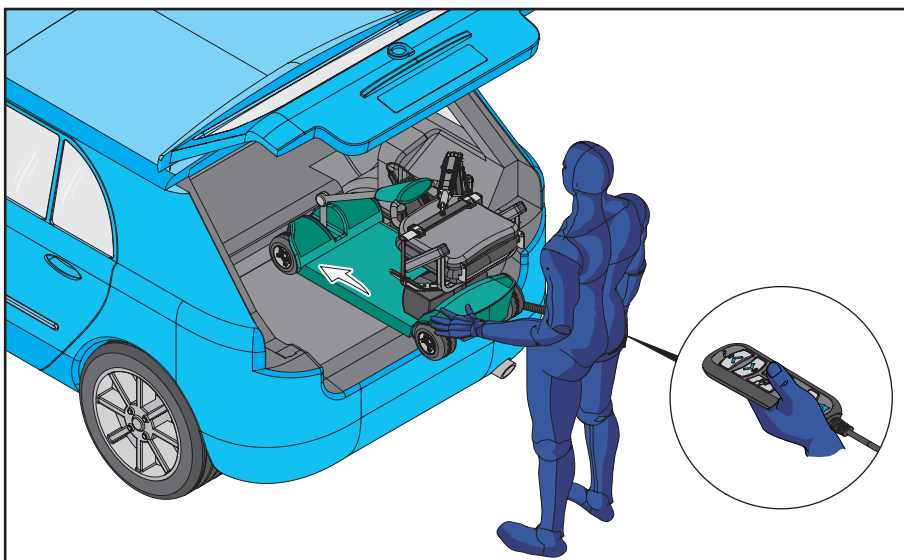

10. Manually guide the mobility device into the boot as shown while holding the IN BUTTON on the handset. Release the IN BUTTON when the mobility device is in the correct position.

## 4. Operation - Loading

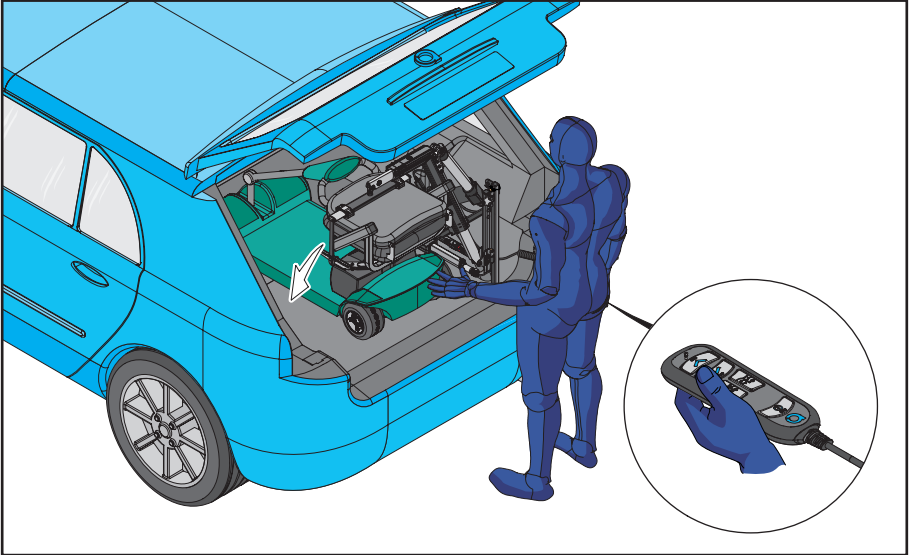

11. When the mobility device is in position in the boot. Press and hold the DOWN BUTTON and guide the mobility device into position. Release the DOWN KEY when the mobility device is grounded on the boot floor.

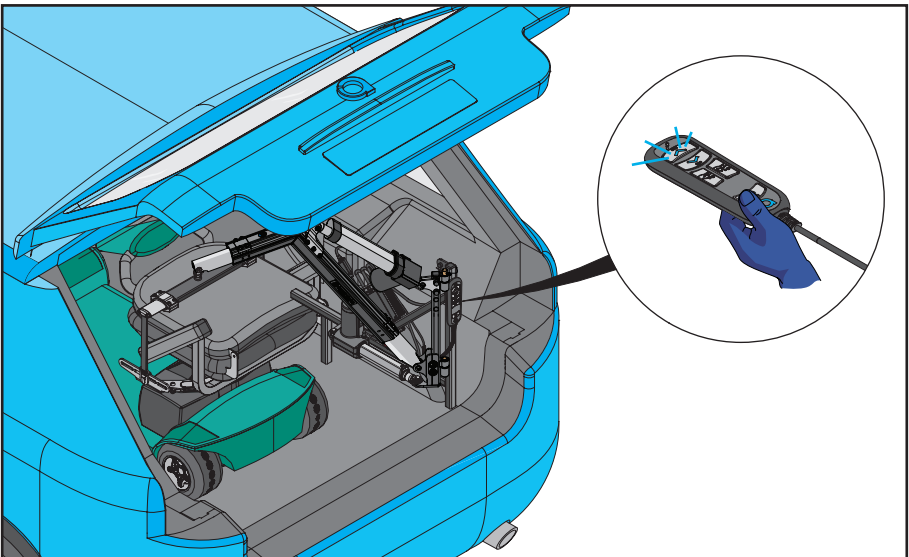

12. Smart Lifter shown in the stowed position. Using the handset press the ON/OFF BUTTON on the remote to turn off the hoist. Replace the handset.



**When lowering the Smart Lifter DO NOT continue to hold the DOWN BUTTON when the Spreader bar is touching the mobility device. This can cause damage to the mobility device and the hoist.**

## 5. Operation - Unloading

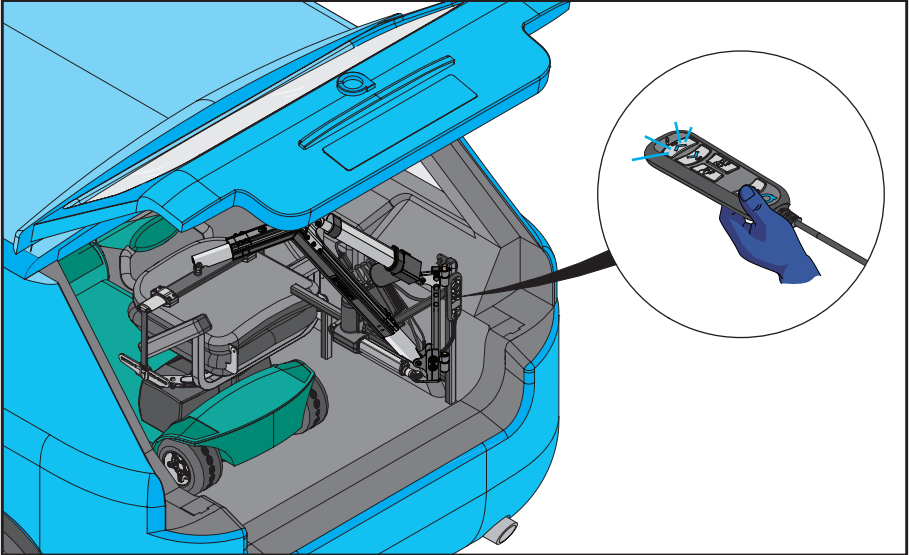

1. Smart Lifter shown in the stowed position. Using the handset press the ON/OFF BUTTON on the remote as shown. This will illuminate the remote and turn on the hoist.

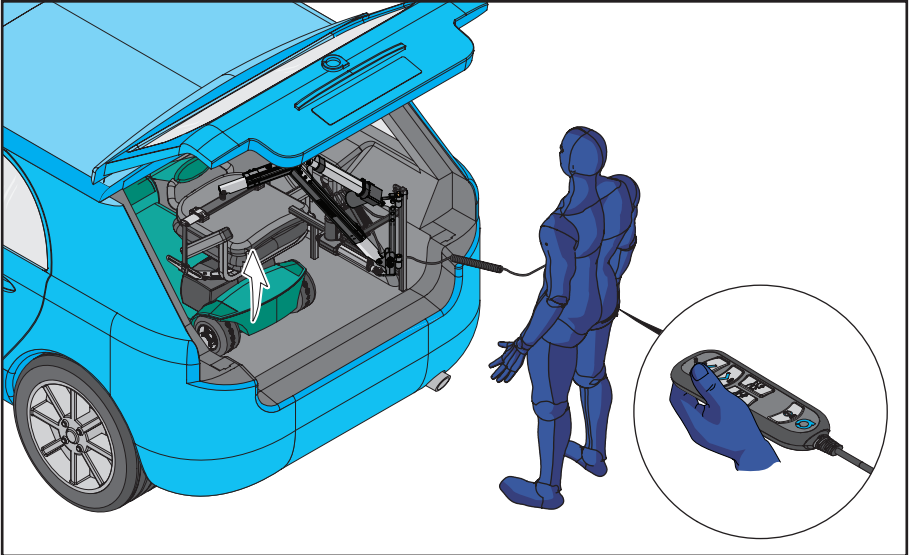

2. To lift the mobility device, press and hold the UP BUTTON on the handset. Release the UP BUTTON when the Smart Lifter is at the highest point in the boot of the vehicle.

## 5. Operation - Unloading

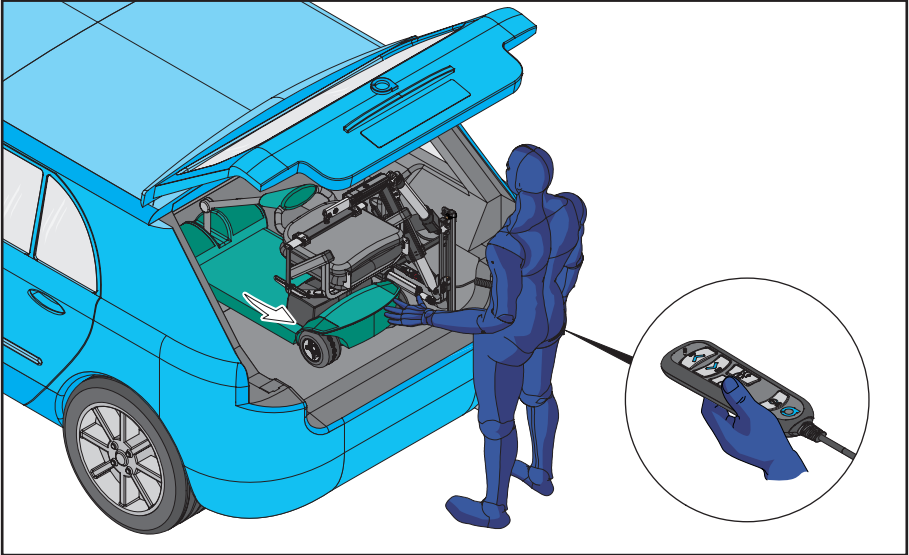

3. Supporting the mobility device with one hand, press and hold the OUT BUTTON on the handset.

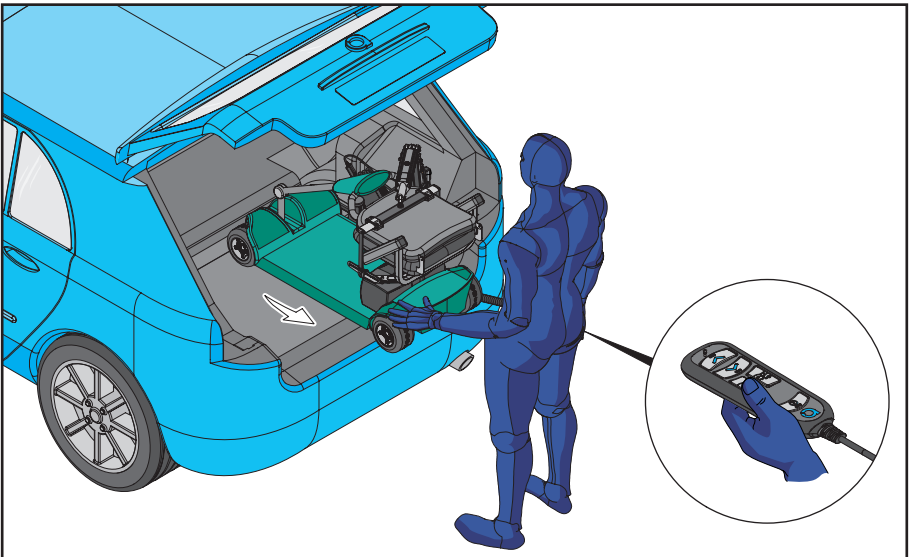

4. Manually guide the mobility device out of the boot as shown while holding the OUT BUTTON on the handset.

## 5. Operation - Unloading

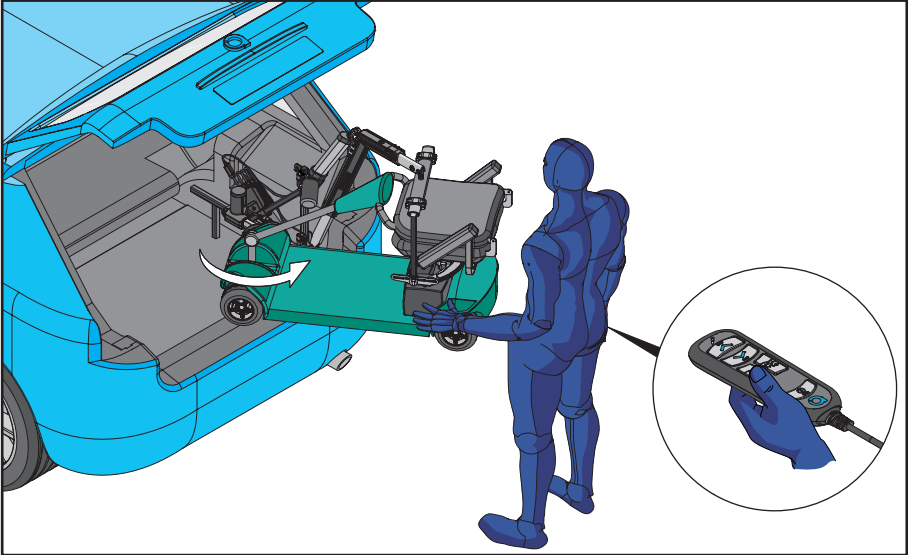

5. Rotate the mobility device out of the vehicle whilst holding the OUT BUTTON. Release the OUT BUTTON when the Smart Lifter is in the fully out position.

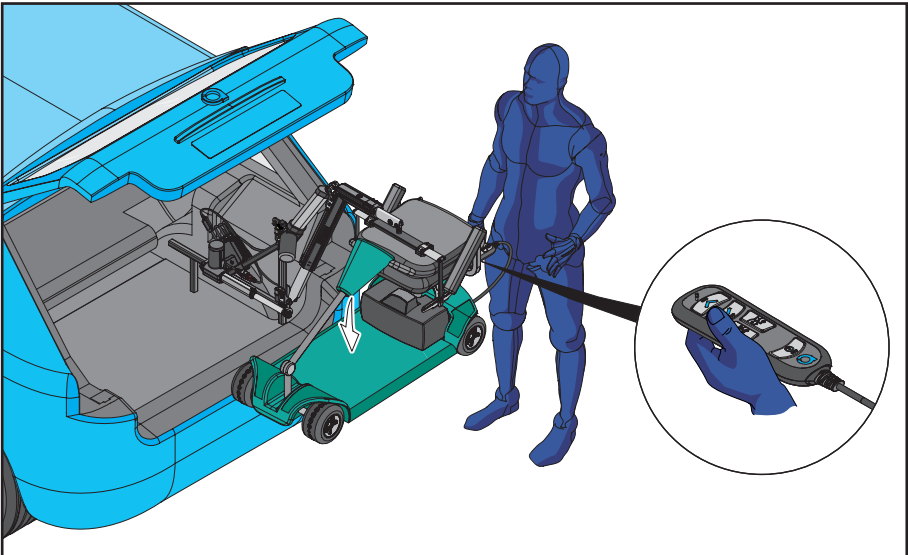

6. Smart Lifter shown in the fully out position. Press and hold the DOWN BUTTON to lower the mobility device. Release the DOWN BUTTON when the mobility device is firmly on the ground.



**When Lifting/Lowering the Smart Lifter do not hold or steady the Smart Lifter Arm.**



**When lowering the Smart Lifter DO NOT continue to hold the DOWN BUTTON when the Spreader bar is touching the mobility device. This can cause damage to the mobility device and the hoist.**

## 5. Operation - Unloading

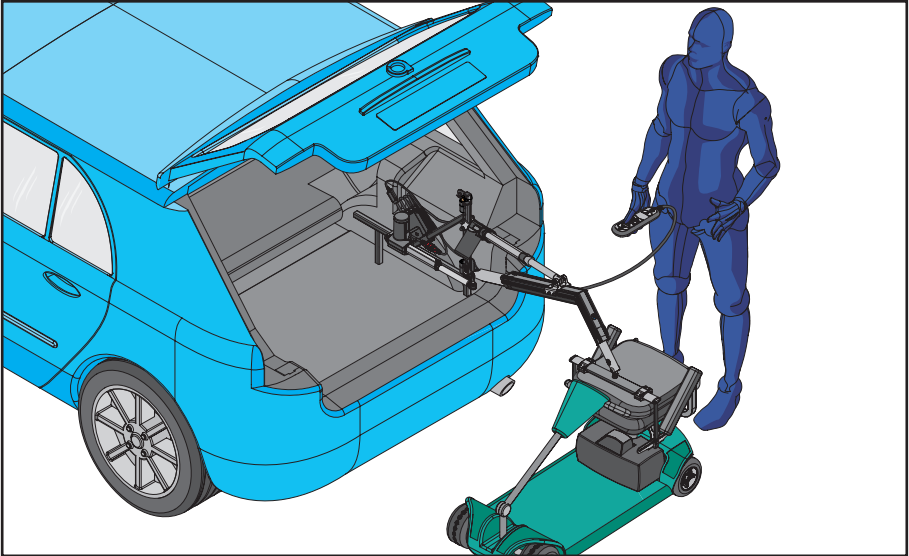

7. Mobility device shown on the ground. Ensure there is some slack on the spreader bar.

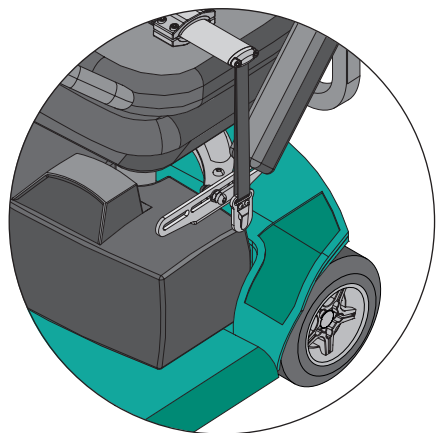
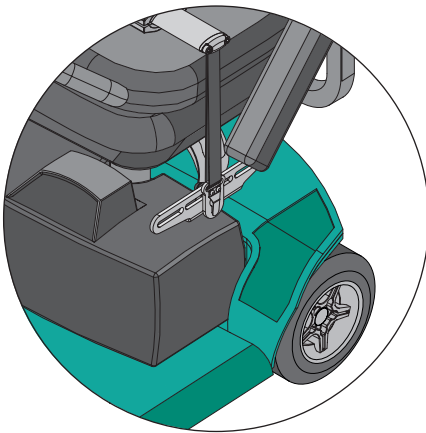

8. Detach the spreader bar from the mobility device.



**When Lifting/Lowering the Smart Lifter do not hold or steady the Smart Lifter Arm.**



**When lowering the Smart Lifter DO NOT continue to hold the DOWN BUTTON when the Spreader bar is touching the mobility device. This can cause damage to the mobility device and the hoist.**

## 5. Operation - Unloading

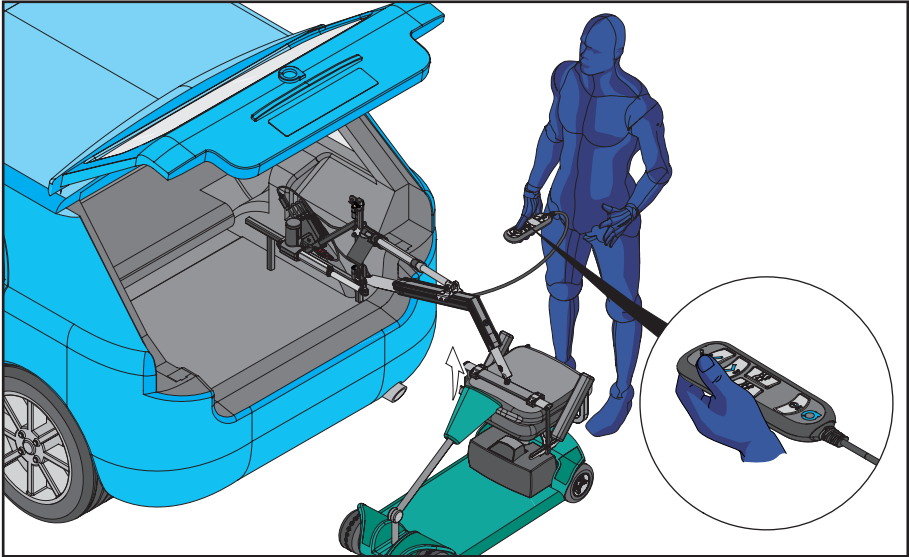

9. When the Smart Lifter is detached from the mobility device, press and hold the UP BUTTON on the handset. Release the UP BUTTON when the Smart Lifter is at the highest point.

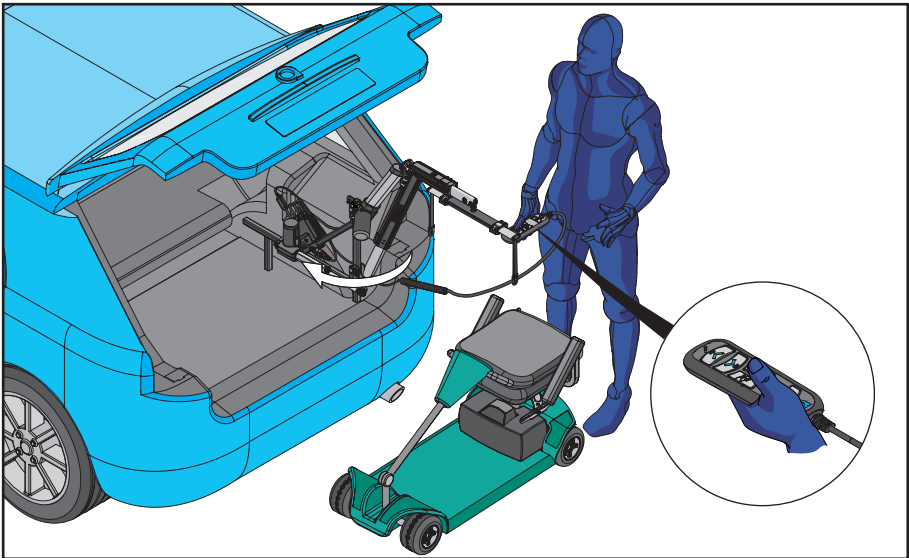

10. Press and hold the IN BUTTON.



The operator should stand a safe distance from the Smart Lifter when it is in operation to ensure that no part of their body is positioned under a raised mobility device.



## 5. Operation - Unloading

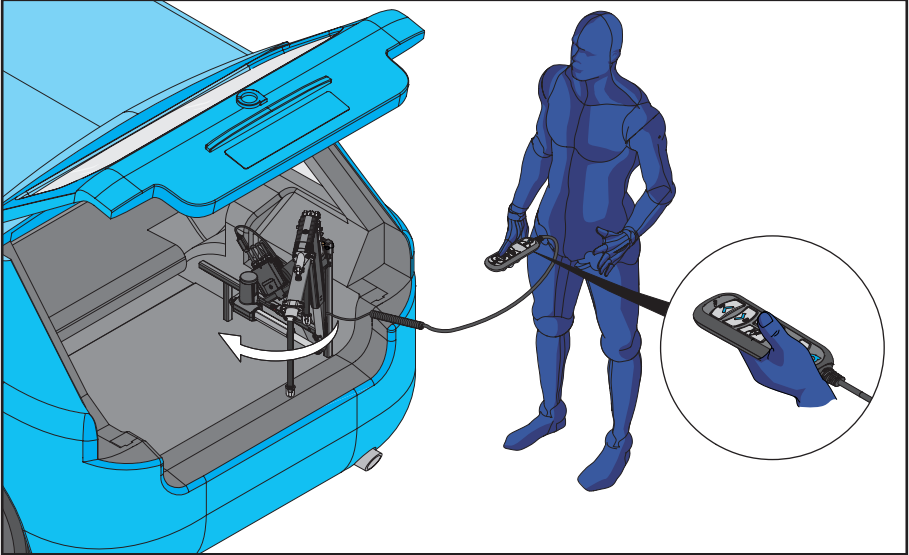

11. Release the IN BUTTON when the Smart Lifter is in the fully in position.

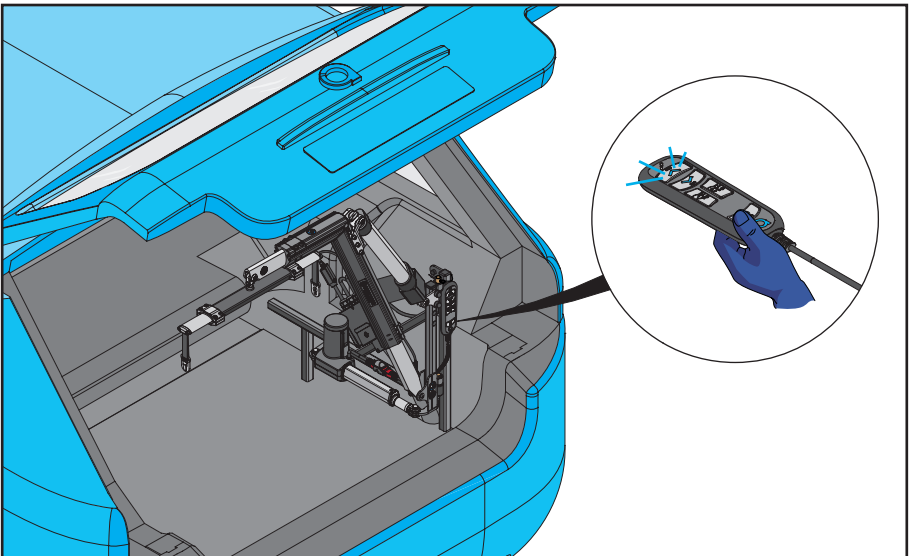

12. Smart Lifter shown in the stowed position. Using the handset press the ON/OFF BUTTON on the remote to turn off the hoist. Replace the handset.



## 6. Removing the Smart Lifter

The following steps show you how to remove the Hoist and Actuator from the A-Frame.

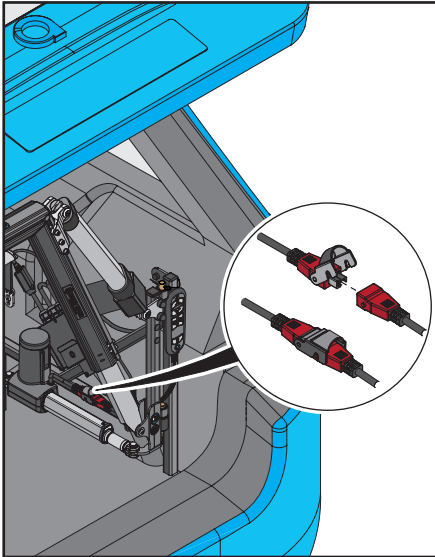

1. Disconnect the Red actuator connector from the Red connector on the control box.

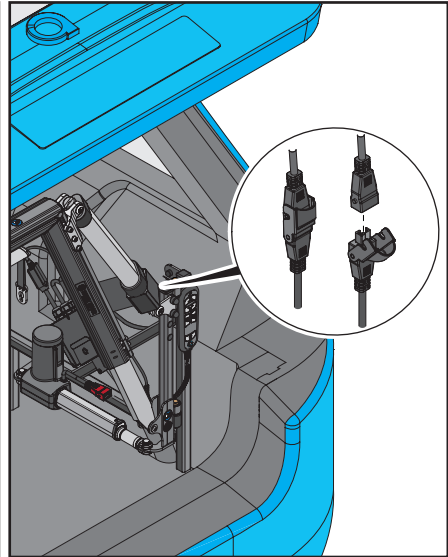

2. Disconnect the Grey UP/DOWN actuator connector from the Grey connector on the control box.

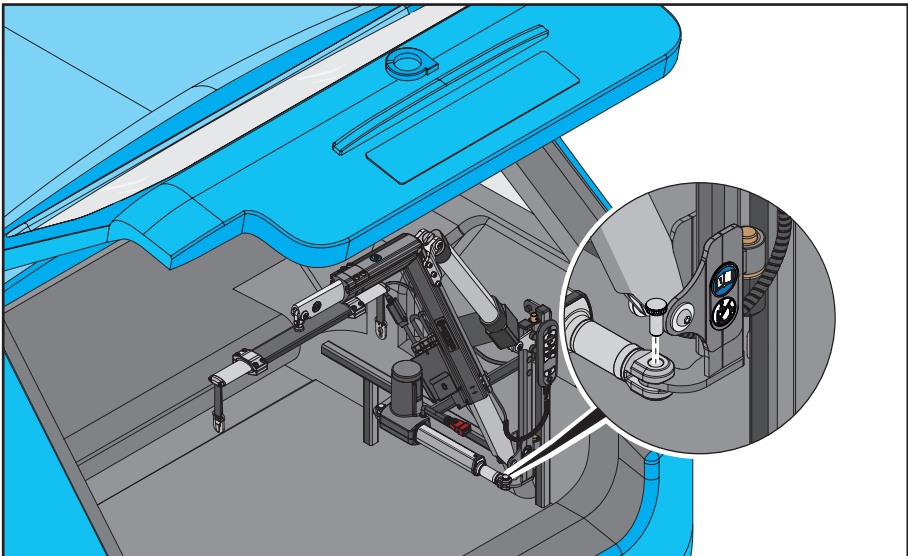

3. Remove the knurled pin from the Smart Lifter and actuator as shown

## 6. Removing the Smart Lifter

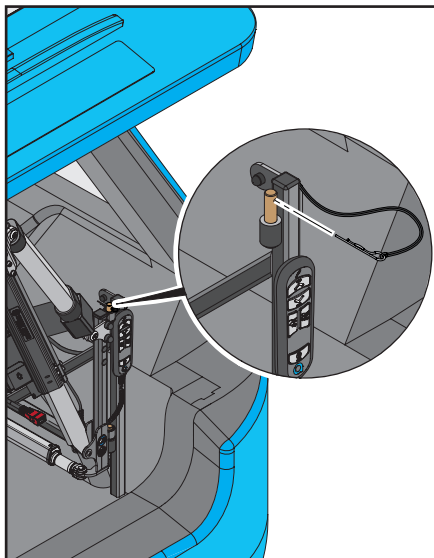

4. Remove the R-Clip from the top pin on the A-Frame/Universal A-Frame.

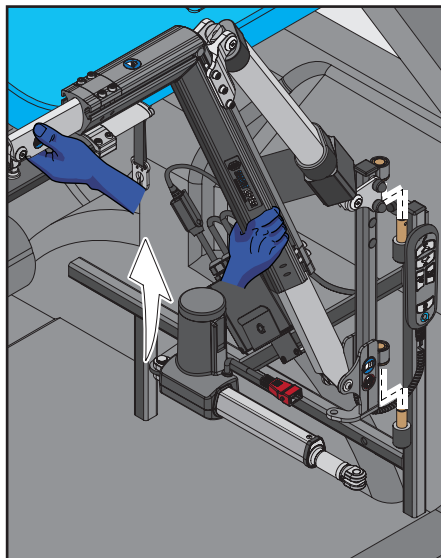

5. Remove the Smart Lifter from the A-Frame/Universal A-Frame as shown.

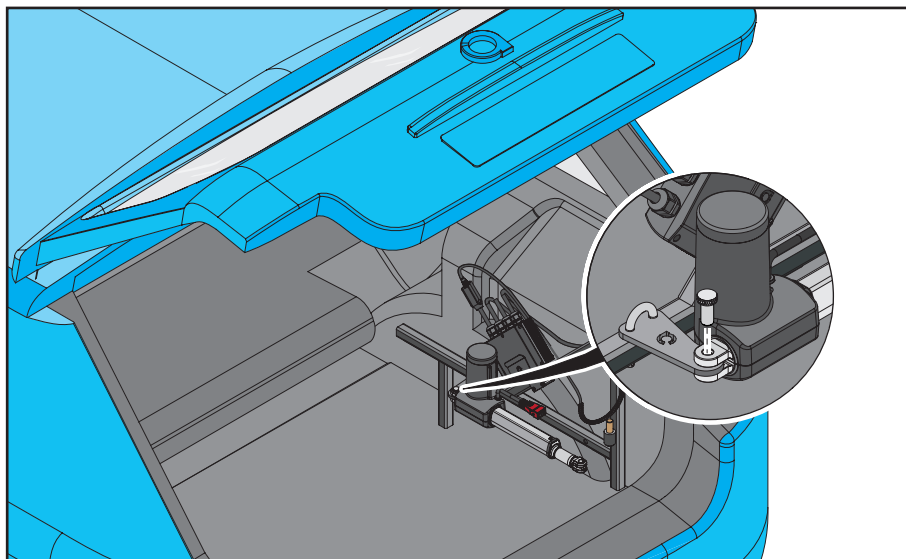

6. Remove the second knurled pin from the actuator and bracket as shown. Remove the actuator by sliding the end off the bracket.

## 7. Replacing the Smart Lifter

The following steps show you how to replace the Hoist and Actuator onto the A-Frame.

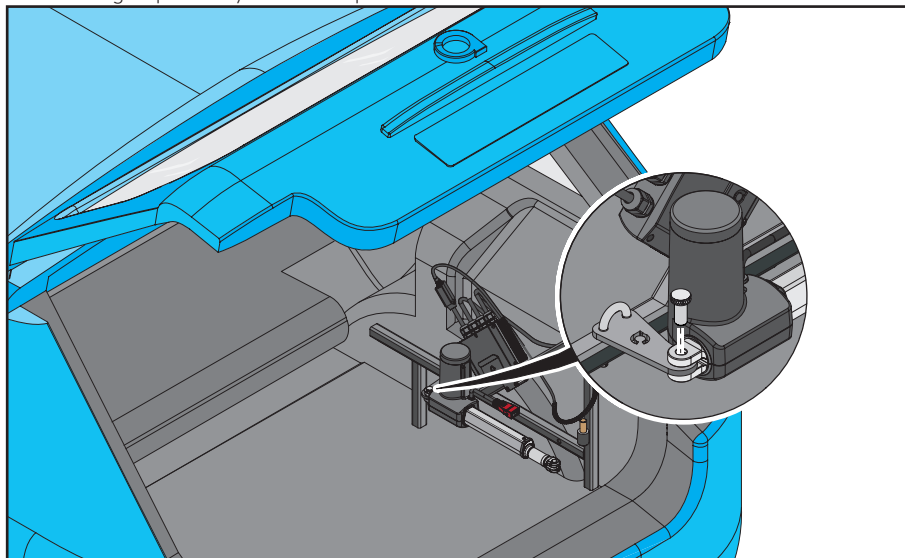

1. Attach the actuator by sliding it over the bracket. Slot the knurled pin into the actuator and bracket as shown.

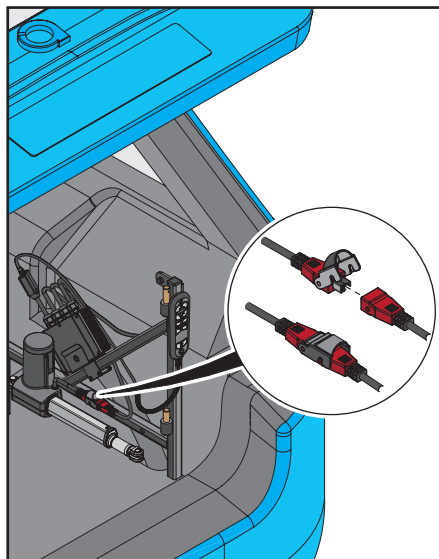

2. Connect the Red actuator connector to the Red connector on the control box.

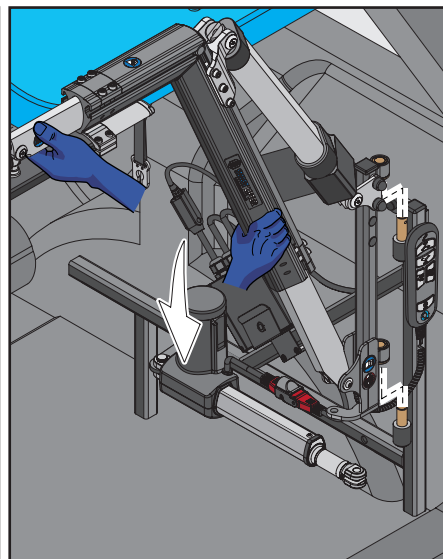

3. Position the Smart Lifter over the Pins on the A-Frame. Rest the lower mounting lug on the longer lower pin before aligning the top pin. Ensure that the Smart Lifter is securely fitted.

## 7. Replacing the Smart Lifter

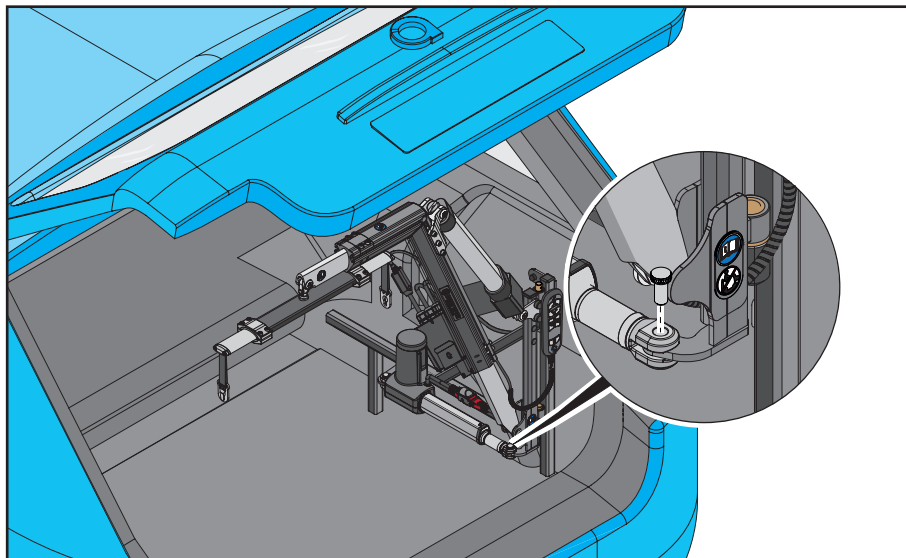

4. Slot the second knurled pin into the Smart Lifter and actuator as shown.

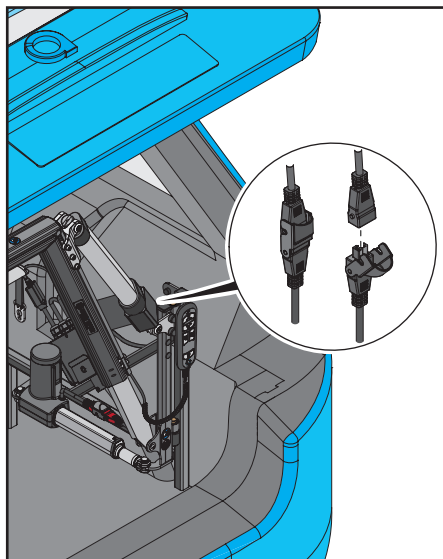

5. Connect the Grey UP/DOWN actuator connector to the Grey connector on the control box.

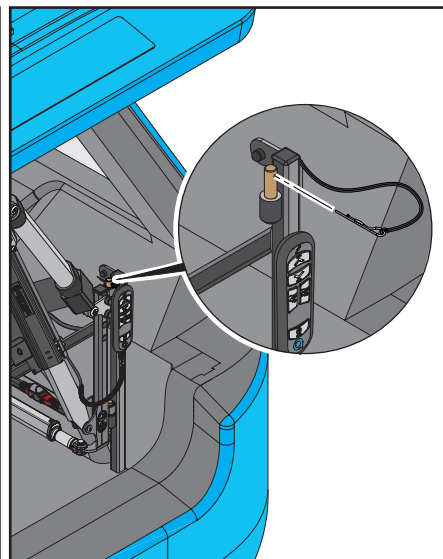

6. Fit the R-Clip in the top pin on the A-Frame. The Smart Lifter is ready to use.

## 8. Troubleshooting

Problem	Solution
No power to the unit	<ul style="list-style-type: none"><li>• Make sure the Smart Lifter is switched on.</li><li>• Turn the Smart Lifter off and back on again and retry.</li><li>• Check the fuse. This is next to the car's battery. A spare fuse is supplied.</li><li>• Is the car battery flat? Try to start the car.</li></ul>
The handset doesn't work	<ul style="list-style-type: none"><li>• Make sure that the Smart Lifter is switched on.</li><li>• Turn the Smart Lifter off and on again and retry.</li><li>• Check the fuse. This is next to the car's battery. A spare fuse is supplied.</li><li>• Is the car battery flat? Try to start the car.</li><li>• Inspect the handset for damage or loose connections.</li><li>• Inspect the cable for damage or wear.</li></ul>
Smart Lifter turns on but won't lift	<ul style="list-style-type: none"><li>• Inspect the actuator power supply. It may have become disconnected.</li><li>• Inspect the electrical plugs between UP/DOWN actuator and power supply, reconnect if they have come apart.</li></ul>
Smart Lifter stops during lifting	<ul style="list-style-type: none"><li>• Has the mobility device been impinged/caught on something preventing movement?</li></ul>
The Smart Lifter lifts very slowly	<ul style="list-style-type: none"><li>• The mobility device weight may be close to the Smart Lifter's weight capacity.</li><li>• Is the vehicle's battery charged? Low battery will cause slow operation.</li></ul>
What if we have an accident?	<ul style="list-style-type: none"><li>• If you think that your Smart Lifter has been damaged in any way please call your Accredited Dealer to arrange an inspection and safety test.</li></ul>

If you can't find a solution to your problem, before operating the Smart Lifter please contact your Accredited Dealer as soon as possible. Their details will be written on the back page of this manual. If you do not have their contact details, get in touch with us and we'll let you know who your Accredited Dealer is and how to get in touch with them.

# 9. Maintenance

## Smart Lifter CARE AND MAINTENANCE

The following routine maintenance should be performed at the indicated intervals. Failure to perform the maintenance procedures at the required intervals may void your product warranty.

### Perform prior to daily use:

- Inspect buckles, straps & fasteners for damage or excessive wear.
- Inspect Smart Lifter for damage or excessive wear.
- Check electrical wires and connections for signs of damage or wear.

Any parts found to be damaged or showing excessive wear should be reported to your Accredited Dealer Immediately.

### Perform at least every 6 months:

- Inspect all mounting hardware and lift pivots for defects and a secure fit.
- Any parts found to be loose or defective should be reported to your Accredited Dealer.

### Perform every 12 months:

- It is recommended that the Smart Lifter is serviced every year by Autochair or your Accredited Dealer.

### Cleaning:

- If required, the Smart Lifter can be cleaned with a damp cloth and detergent. Ensure the unit is disconnected from the power before cleaning.

**Do not immerse in water, do not allow water to run into the electrical connectors or control box and allow to dry before use.**

# 10. Warranty

## PRODUCT WARRANTY

The warranty period for the Smart Lifter is detailed in your contract.

This warranty will cover **any defects of workmanship or function.**

The warranty **does not cover any incorrectly installed Smart Lifters** or one with damaged mechanical or electrical components due to **incorrect use or damage.**

The warranty does not cover consequential direct and indirect loss, unless regional law requires it.

The warranty is invalidated if the seal on either the actuator or control box is broken. These contain no user replaceable components.

No alteration should be made to the Smart Lifter by anyone other than a qualified person, as defined by an Accredited Dealer.

In the event of damage or defects in the actuator or motor, the Smart Lifter should be returned to your Accredited Dealer for evaluation.

No wires must be cut as they are fitted with connectors that must be correctly removed before repair.

In the event of any malfunction of the electrical circuit box or handset which require replacement, please contact your Accredited Dealer.

Please fill out the following details for quick reference:

Dealer: \_\_\_\_\_

Address: \_\_\_\_\_

\_\_\_\_\_

\_\_\_\_\_

\_\_\_\_\_

Post Code\Zip Code: \_\_\_\_\_

Phone Number: \_\_\_\_\_

Purchase Date : \_\_\_\_\_

Serial Number: \_\_\_\_\_



**SMART  
LIFTER**  
Range

